

# The NorCal Paddle Kit

designed by  
Wayne Smith, K8FF

Winner of the 1997 NorCal Design Contest  
Kitted by the NorCal QRP Club

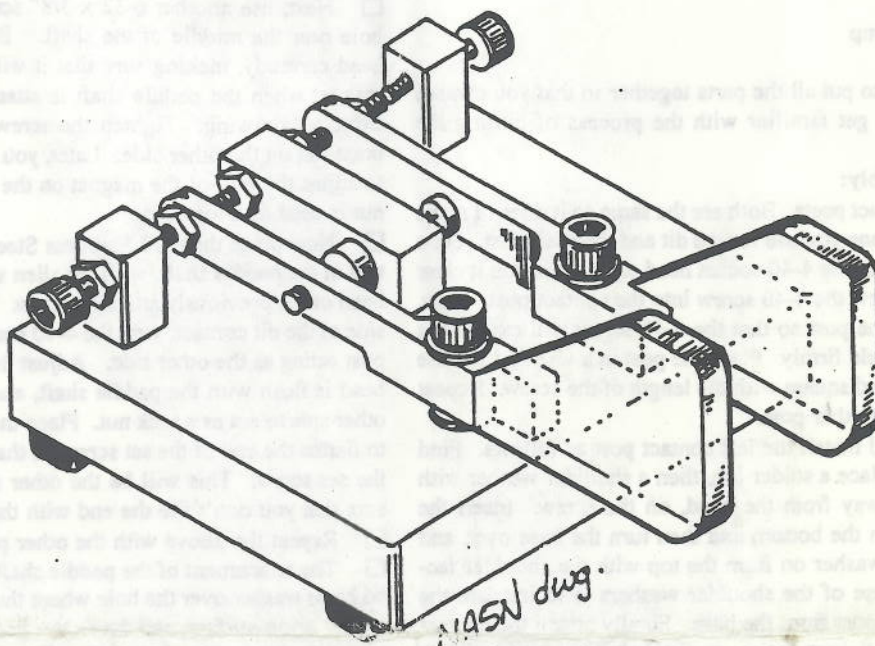

©1997 All Rights Reserved. This manual is copyrighted by Doug Hendricks of the NorCal QRP Club and no part of this manual may be reproduced in any form without the expressed written permission of Doug Hendricks.

Thank you for purchasing the NorCal Paddle kit designed by Wayne Smith, K8FF. Wayne lives in Ohio, and submitted the kit design for the NorCal Design Contest. When I first saw this design I knew that we had to kit this one. Therefore we were able to start kitting early and get a jump on things so that we could have the kit ready for introduction at Pacificon. Congratulations to Wayne for designing a great project.

This kit contains all of the parts needed to produce a high quality iambic paddle that you will be very proud of and pleased to use. Since most of us don't have a machine shop in the garage, NorCal contracted with San Luis Machine Company to provide the machined parts. The parts are machined but they are not polished. No power tools are needed to finish the kit. It can be done entirely by hand.

One member who saw the kit suggested to me that it was like a black powder rifle kit. The parts are all there, what the final product looks like will depend on the amount of time and effort that you spend putting it together.

Paul Harden, NAST, has kindly produced an excellent exploded drawing of the paddle. There is an interesting story to this drawing. Paul did it by lantern light at Fort Tuthill on a piece of scratch paper. He then returned home and produced the beautiful drawing that is included in this manual. You will find it invaluable in putting to-

gether the kit.

#### Construction:

□ Step 1 Inventory the parts that are in the kit. Most of the hardware parts are commonly found in your local hardware store. If we have left out a part, let us know and we will provide it, but keep in mind that if it is a simple nut or washer, you can probably get it locally and not have to wait to finish your kit. The best way to let us know is to email me at the following address:

ki6ds@telis.org

If you don't have email, send me a letter at the following address:

Doug Hendricks  
862 Frank Ave.  
Dos Palos, CA 93620

Ok, time to check off the parts. Use the exploded view to help in parts identification.

- 1 Base
- 1 Center Block
- 1 Dit Paddle Shaft
- 1 Dash Paddle Shaft
- 2 x Contact Post
- 2 x Plastic Handle
- 2 x Bushing 3/8 x 1/4

- 2 x 4-40 x 3/4 SS Socket Head
- 2 x 4-40 Brass nut
- 8 x 6-32 Brass nut
- 2 x 6-32 x 3/4 Socket Head
- 3 x 6-32 x 3/4 Screws
- 1 x 6-32 x 1 Screw
- 4 x 6-32 x 3/8 Screws
- 4 x #6 Brass Washer
- 2 x 6-32 SS Set screw
- 2 x 6-32 Set screw
- 1 x Magnet
- 4 x #6 Shoulder washer
- 3 x #6 Solder lugs
- 4 x Rubber Feet
- 1 x 1/8" Cable clamp

The next step is to put all the parts together so that you can see how it will look and get familiar with the process of putting the paddle together.

#### Contact Post Assembly:

There are 2 contact posts. Both are the same so it doesn't make any difference which one you use for the dit and the dash post. Put a 4-40 brass nut on one of the 4-40 socket head screws and run it clear to the top. Next, screw the 4-40 screw into the contact post. Now, back the nut against the post so that the 4-40 screw will extend out the other side yet be held firmly. Place the post in a vise and file the end of the screw flat and square with the length of the screw. Repeat this operation with the other post.

Take the base and install the left contact post as follows. Find a 6-32 x 3/4" screw, place a solder lug, then a shoulder washer with the shoulder facing away from the head, on the screw. Insert the screw in the base from the bottom and then turn the base over, and put another shoulder washer on from the top with the shoulder facing down. The purpose of the shoulder washers is to insulate the screw and the contact post from the base. Finally attach the contact post assembly and tighten the screw, firmly but not "super tight". Make sure that you align the 4-40 Stainless screw with the front edge of the base so that it will point towards the center magnet assembly. Repeat with the other contact post.

#### Center Magnet Assembly:

Our next step will be to assemble the center magnet assembly. Find the magnet in the parts bag, and place it on top of the center assemble centering it so that the same amount extends on both sides. The magnet is a press fit, and we will do that later. Right now you are just getting an idea of how the paddle goes together. Set the magnet aside.

Now find one of the 6-32 black set screws. Put a 6-32 brass nut on it, run it up on the screw about half way, and insert it where it goes on the center magnet assembly. Repeat with the 6-32 black set screw that goes on the other side. If this sticks out too far for you, you may want to file the ends of the screw down to shorten it. This completes the preliminary assembly of the center magnet assembly. Now, take the assembly and set it aside.

Find two of the 6-32 brass nuts and drill them out with a 9/64" drill bit so that they will slip over a 6-32 screw. You are going to use them as spacers, so the threads need to be drilled out.

Next, use a 6-32 x 3/4 screw to attach the front part of the assembly to the base. The screw that is nearest the center of the base. Place a solder lug on the screw and then place it in the base. Align the center magnet assembly as shown in the exploded drawing and tighten the screw. We purposely made the holes bigger than they needed to be to allow for alignment of the center block.

Find the 6-32 x 1" screw. Use a file or a grinder to shorten it to

7/8". The 1" screw is too long, and the 3/4" one is too short. So, you need to adjust the length with a file or grinder. [This is a kit, after all.] Use your new "custom length screw" to attach the other side of the center assembly. This screw will be nearest the edge of the base. Put the cable clamp on the screw and then insert it in the hole and tighten. Set the paddles aside.

#### Dit and Dash Paddle Shafts:

Locate the dit paddle shaft from the machined parts. Make sure that you have the dit paddle shaft and not the dash, as they are mirror images of each other and are easily confused. Use a 6-32 x 3/8" screw to attach one of the plastic handles to the shaft as shown in the exploded view. Don't tighten the screw too tight as you will break the plastic.

Next, use another 6-32 x 3/8" screw and thread it through the hole near the middle of the shaft. Be sure to orientate the screw head correctly, making sure that it will be on the same side as the magnet when the paddle shaft is attached to the base, refer to the exploded drawing. Tighten the screw all the way and put a 6-32 brass nut on the other side. Later, you will be able to use this screw to adjust the pull of the magnet on the arm to your preference. The nut is used as a lock nut.

Now place the 6-32 Stainless Steel set screw in the hole on the end of the paddle shaft, with the allen socket on the same side as the head of the previously attached screw. This set screw will act as one side of the dit contact, with the 4-40 socket head screw in the contact post acting as the other side. Adjust the set screw so that the socket head is flush with the paddle shaft, and put a brass 6-32 nut on the other side to act as a lock nut. Place the shaft in a vise and use a file to flatten the end of the set screw so that it is square with the shaft of the set screw. This will be the other side of your contacts. Make sure that you don't file the end with the allen wrench socket on it.

Repeat the above with the other paddle shaft.

The attachment of the paddle shafts to the base is next. Place a #6 brass washer over the hole where the paddle shaft goes. This acts as a bearing surface and gives the paddle shaft clearance with the top of the base. Due to the manufacturing process used, one side of the washer is slightly convex, the other side is slightly concave. This is actually a plus for this application. To find the concave side, take the washer and carefully feel the edges with your finger. The side that is concave will feel "sharp". Place the convex side against the paddle shaft, both on the bottom and the top. This will give you the necessary clearance. Find one of the 3/8" long by 1/4" bronze bearings and place it in the hole of the shaft where it goes. Refer to the exploded drawing. This bearing is very important to the "feel" of the paddles. You will adjust it later.

Now take one of the 6-32 x 3/4" socket head screws and put a #6 brass washer on it, again making sure that you have the convex side of the washer against the paddle shaft. Then attach the dit paddle to the base with the socket head screw, which acts as a pivot for the arm. The arm should fit easily into the space provided. Be sure to back the 4-40 socket head screw out of the contact post to give you enough clearance.

Repeat the above operation with the other paddle shaft.

Your paddle is now complete and should look like the exploded drawing. Take a moment and admire your work. Next, adjust the contact points to your liking. One suggestion is to use an allen wrench and a small wrench to hold the locknut. I tighten the screw until it just touches the other contact, then back it off about 1/16 of a turn, and tighten the lock nut while holding the shaft with the allen wrench.

Now test the action of the paddles. It is not exactly what you had in mind is it? No, because you haven't tuned or "blueprinted" your paddles. Note that there is some up and down movement of the paddle arms. That is because of the play between the top of the

bearing and the shaft. What you need to do is reduce this "play". Get a set of "feeler" gauges that are used by an automobile mechanic to set points and valve clearance. Use them to measure the clearance between the washer and the paddle shaft. Or you can use a micrometer or a dial caliper to measure the thickness of the paddle arm and the length of the bearing. I found that mine were .005" difference when I started. I carefully filed the bearing down until the clearance was .002" and it was just right. Make sure that you take the bearing out of the shaft to file it. Take your time and test fit. DO NOT go too far or your bearing will not work, and you will have ruined your bearings. I was able to adjust mine to .001". Be careful, we do not have extras.

Replacement bearings are available from San Luis Machine Company, but they are a special order item. The cost is \$2.00 per bearing, and they ask that you include a self addressed mailing label. To order replacement bearings send \$2 per bearing plus the mailing label to:

San Luis Machine Company

Unit F2

200 Suburban Rd.

San Luis Obispo, CA 93401

After you have the feel just right it is time to finish your paddles. Disassemble the paddle being very careful to not mix up the paddle shaft parts. Keep the bearings separate and always with the same shaft. Take the magnet out for now. I used a buffer and polishing rouge. It took about 5 hours to finish the brass parts just right, but it was worth it. Another method of finishing the paddles is to use #400 grit wet/dry sandpaper from an auto supply store and WD40 as a lubricant. This will give it a satin finish that looks very nice also. And there will be those of you who will have them plated, either chrome or even gold or silver, the choice is yours.

To finish the plastic handles, take a fine file or 100 grit sand paper and lightly sand the edges after grinding or cutting them to shape. If you want to cut off one of the corners as in the drawing, use a hack saw and a vise. When you are satisfied with the shape, take the paper off the paddle handles and buff the edges to polish them clear. Paul Harden, NASH passes along this tip. When you get the saw marks out, put water on the edges and use 220 grit sand paper to polish the edges to a crystal clear finish. It will just take a few strokes of sandpaper.

We coated the base with WD40 to keep it from rusting, so you will want to degrease it before painting or finishing. We used hot rolled steel for the base, and it has a rough surface that needs to be smoothed before you finish it. We suggest that you go to the hardware store and buy some 80 grit sand paper. Place the sand paper onto a surface that is nice and flat, either a table saw top or a piece of glass. Then holding the base with the upper side down, sand it in a circular motion, making sure that you keep the surface flat at all times. Do not use a power sander here, as you will get dips and valleys which will affect the final outcome of your paddles. When you have it as smooth as you want it, then paint it with sandable metal primer, and follow the directions on the can to finish the base. If you paint it make sure to use some spare 6-32 screws so that you don't get paint in the two threaded holes.

When you are satisfied with the finish of the center assembly, it is time to press fit the magnet. Don't be alarmed. This is a simple operation. Place the center assembly in a vise, with two pieces of wood to straddle the magnet hole and give the magnet clearance when it comes through. Then, carefully place the magnet at the start of the hole, and slowly close the vise to press the magnet in. Eyeball it and try to get the magnet with the same amount sticking out of both sides. Don't worry, if you go too far, just turn it over and push it back. On some of the kits the fit will not require press fitting, and all that will be required is to place a drop of super glue on the magnet and slide it into the hole. Just don't do it until after you have finished polishing the center block.

To keep your paddles looking brand new with a mirror surface, use Mother's metal polish available from any auto parts store. It is

used to polish mag wheels, but works great on the brass and metal parts.

Now it is time to reassemble the paddles. Start with the center assembly. Note that the holes that the mounting screws go in have some play, about .015" in fact. This was done on purpose in order to give you room to adjust the center assembly to fit square to the edge of the paddle base. When you have it just right, tighten the screws snug but not tight. Then assemble the contact posts. Now adjust the 4-40 screws so that they are flush with the edge of the post. This will give us room to fit the dit and dash arms in.

The next step is to wire the paddles. Refer to the exploded diagram. One hint: solder the wires to the solder lugs and then attach the solder lugs, otherwise the paddles act as a huge heat sink and they are hard to solder. Run the cable through the cable clamp, tighten the clamp and run the wires to the appropriate screws.

Attach the feet as shown in the diagram. Press them on hard and they will stick to the surface, but it is important that all oil and grease have been removed.

Finally, adjust your paddles to your liking. Congratulations you have just finished your kit. We hope that you enjoy it, and if you come up with any mods or suggestions, we would like to hear from you. 72, Doug, KI6DS and Jim WA6GER, NorCal QRP Club.

If you are interested in a powder coated base, San Luis Machine has them available. This will save you the hassle of finishing your base. You will receive a beautifully painted base with a hard, durable paint coating that has been baked on. The cost is \$20 + \$5 shipping and handling. Colors available include Red, Blue, Black and White. There is a wait of up to 6 weeks as the bases are run in with other jobs to keep the costs down. You may still use your old base until the new one arrives, it just won't look quite so nice!! To order send a check or money order for \$25 (\$20 + \$5 S&H) to:

San Luis Machine Company

Unit F2

200 Suburban Rd.

San Luis Obispo, CA 93401

Please remember to include a self-addressed mailing label with your order.

If you are interested in a keyer kit to go with your paddles, Embedded Research has several iambic keyer kits that are very good, and very inexpensive. They have the following kits available including parts, board and manual.

- TiCK-1 Chip + datasheet (\$5 postage paid within the US) •TiCK-1 Chip + manual, and Circuit Board (\$10 ppd within US) •TiCK-1 Chip + manual, Circuit Board, and Parts (\$16 ppd within US)
- TiCK-2 Chip + datasheet (\$10 postage paid within the US)
- TiCK-2 Chip + manual, and Circuit Board (\$15 ppd within US) •TiCK-2 Chip + manual, Circuit Board, and Parts (\$21 ppd within US)
- TiCK-2B Chip + datasheet (\$12.50 postage paid within the US)
- TiCK-2B Chip + manual, and Circuit Board (\$17 ppd within US)
- TiCK-2B Chip + manual, Circuit Board, and Parts (\$23 ppd within US)

The TiCK-X DIP parts kit includes: Board mounted parts: 5v regulator, 5 capacitors, 3 resistors, 1 PN2222, 1 8 pin DIP socket. Off-board parts include 1 piezo audio device, 1/8" mono jack, 1/8" stereo jack, & 1 N.O. momentary switch.

The TiCK-X SOIC parts kit includes: Board mounted parts: 2 capacitors, 2 resistors, 2 transistors, and solder. Off-board parts include 1 piezo audio device, 1/8" mono jack, 1/8" stereo jack, & 1 N.O. momentary switch. We include doubles of the cap, resistor, and transistor for your convenience. NYS Residents please add 8% sales tax to purchase price. Orders to continental US, postage paid. Western Europe and Canada, add \$4. Pacific Rim add \$6. Send to: Embedded Research, PO Box 92492, Rochester, NY, 14692. Checks in \$US.

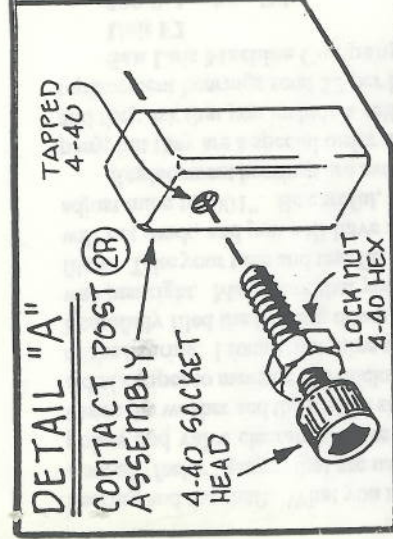
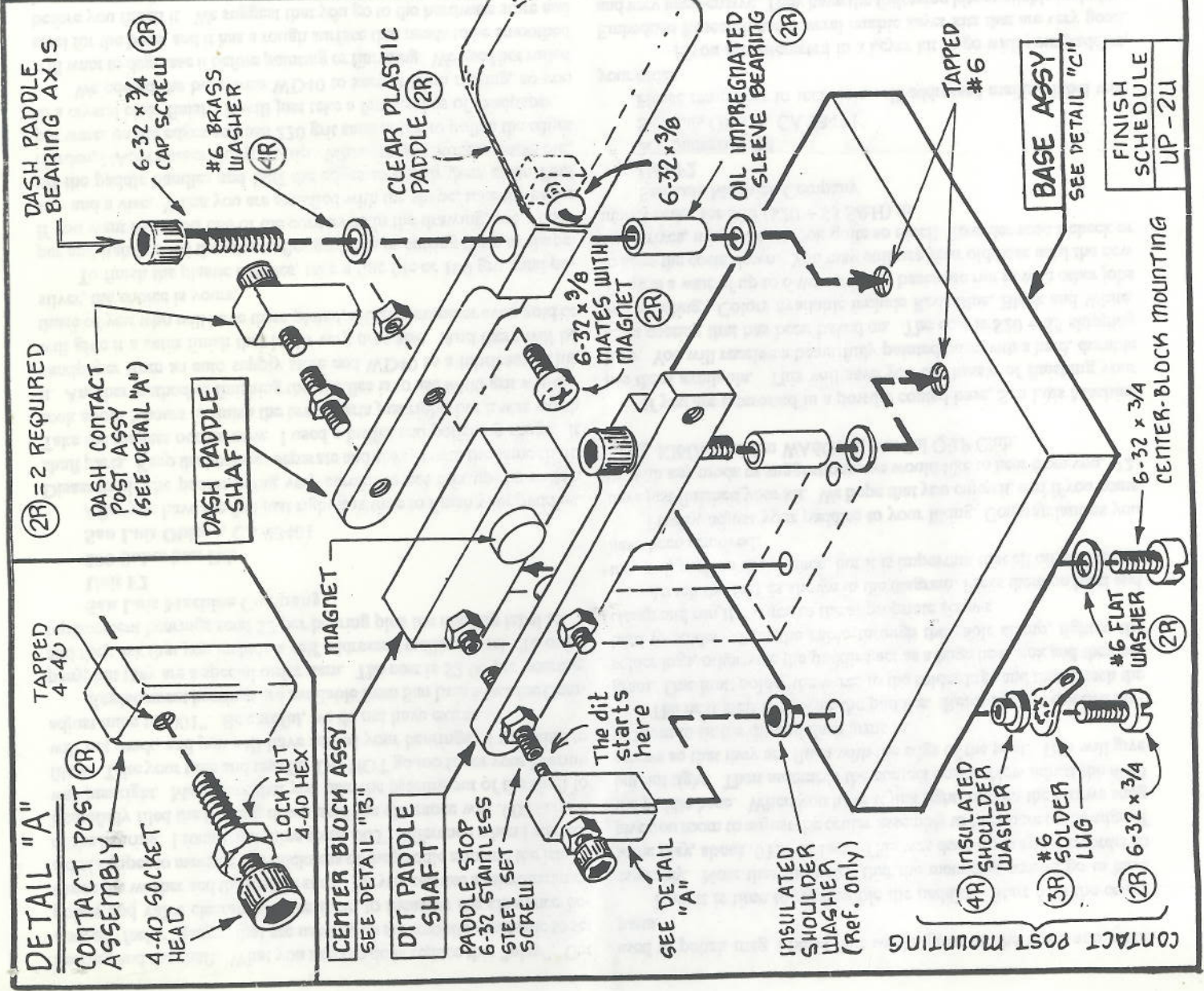
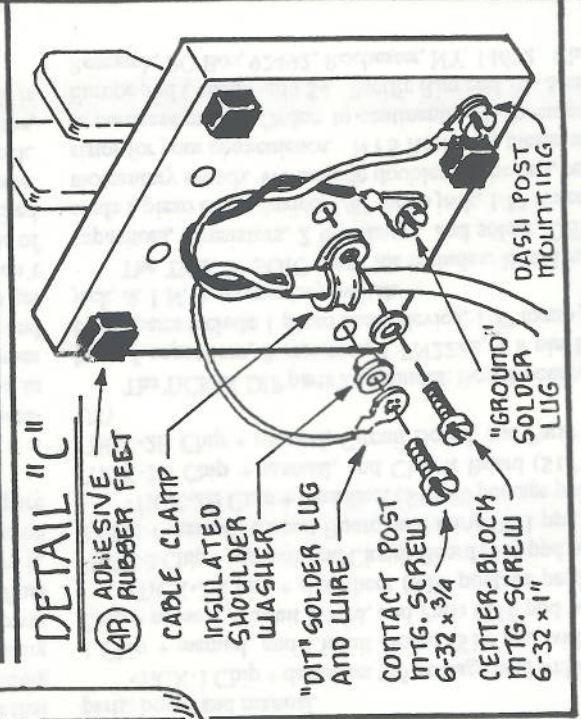
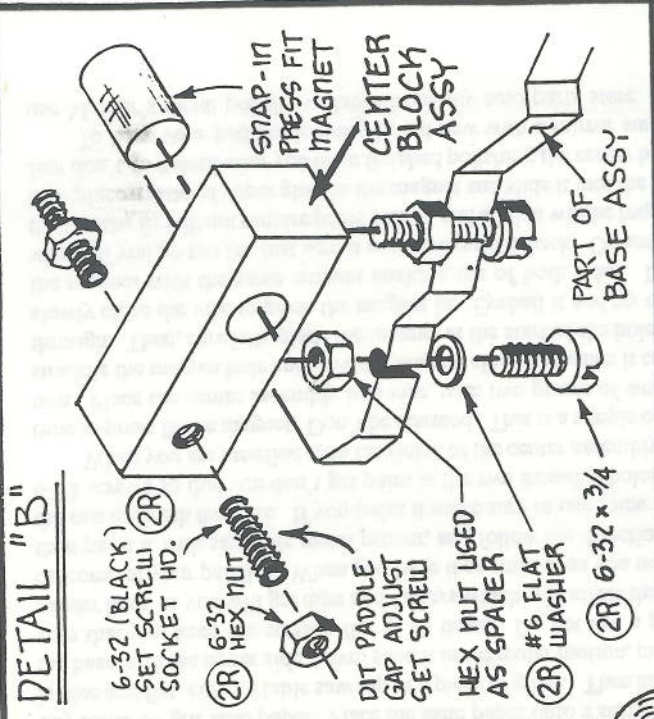

<b>The NORCAL PADDLES</b>		<b>NORCAL QRP CLUB</b>	
Morse Code Semi-Automatic Keyer Paddles	DESIGNED BY: Wayne Smith, K8FF	DRAWN BY: NA5N	APPROVED BY: KI6DS
DWG. NO. K8FF-KEY	DWG. SIZE A	SHEET NUMBER 1 of 1	RELEASE DATE OCT. 1997

©1997, NorCal QRP Club